

## A reusable metal crucible for use in differential scanning calorimetry analysis of closed reaction system samples<sup>1</sup>

L. Tuma

*Merck, Sharp & Dohme Research Laboratories, P.O. Box 2000, Rahway, NJ 07036 (USA)*

(Received 26 June 1991; accepted 8 May 1992)

### Abstract

A specially designed sample crucible has been developed and evaluated for use with differential scanning calorimetry to determine whether if an exotherm is present in a closed system without the use of a high pressure DSC cell. The problems associated with the use of a crimped aluminum sample pan, with its low pressure containment and chemical reactivity, are overcome with the use of these crucibles. This crucible eliminates the need to purchase a high pressure DSC cell, in which the chemically reactive aluminum pan is often used, and overcomes the high pressure DSC problems of duplication of results and noisy baselines. The crucibles are useful with samples containing volatile components or those which release gaseous by-products during decomposition. The crucibles are constructed of either 316L or Hastelloy B, have a volume of  $\approx 60 \mu\text{l}$ , and have a removable glass liner for use with highly corrosive systems. The crucibles are reusable, with a screw-on cap containing a replaceable 400 psi “rupture disk” seal, and have an operating temperature range from  $< 0$  to  $\approx 300^\circ\text{C}$ . Many of the commercially available high pressure cells are not reusable, do not have chemically resistant liners and are difficult to seal properly. The determination of the calibration coefficient of a DSC cell using this sample crucible, both with and without the glass liner, will be presented and the value compared with the calibration coefficient determined using a typically sealed aluminum pan.

### INTRODUCTION

A critical aspect in the development of any chemical process is the early identification of the thermal hazards associated with the process. Differential scanning calorimetry is a technique frequently used to determine quantitatively if an exotherm is present in a closed system, which may result in thermal process hazards. Typically, high pressure DSC or crimped

---

*Correspondence to:* L. Tuma, Merck, Sharp & Dohme Research Laboratories, P.O. Box 2000, Rahway, NJ 07036, USA.

<sup>1</sup> Presented at the 20th Annual NATAS Conference, Minneapolis, MN, 20–26 September 1991.

aluminum pans are used to determine if exotherms are present in a closed system. The problems associated with the use of a crimped aluminum sample pan, with its low pressure containment and chemical reactivity, are overcome with a specially designed sample crucible, the Merck “closed bomb” (CB). This crucible eliminates the need to purchase a high pressure DSC cell, in which the chemically reactive aluminum pan is often used, and overcomes the high pressure DSC problems of duplication of results and noisy baselines. Many of the commercially available high pressure cells are not reusable, do not have chemically resistant liners and are difficult to seal properly. The design of this reusable CB is shown in Fig. 1; it consists a screw-on cap, with a replaceable Teflon rupture seal, which is 20  $\mu\text{m}$  thick and can withstand a pressure of approximately 400 psi, and a threaded bottom. The CB is made of either Hastelloy B or 316L stainless steel, to provide overall corrosion resistance, and is  $\approx 0.25$  inches in diameter and has a capacity of  $\approx 60.0 \mu\text{l}$ . The closed bomb has an operating range from 0 to  $\approx 300^\circ\text{C}$ . A specially designed set of wrenches (Plate 1) is used in holding the bottom of the CB assembly and in tightening the cap.

A removable glass liner is available for use with highly corrosive samples. The glass liner is made from 4.0 mm diameter glass tubing, which is cut into 6.5 mm lengths and is sealed at one end. Both the top and the bottom of the glass liner are hand ground to fit inside the CB cell and to fit flush with the bottom of the CB. These liners have a capacity of  $\approx 20 \mu\text{l}$ . A second Teflon seal, 4.0 mm in diameter and 10  $\mu\text{m}$  thick, is placed on the top of the glass liner before the CB lid is put in place.

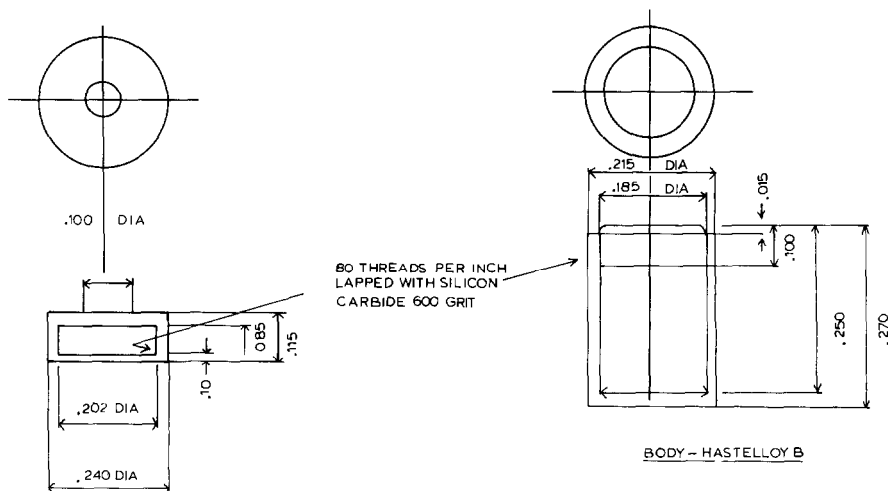

CAP - 316 L STAINLESSSTEEL

Fig. 1. The reusable closed bomb.

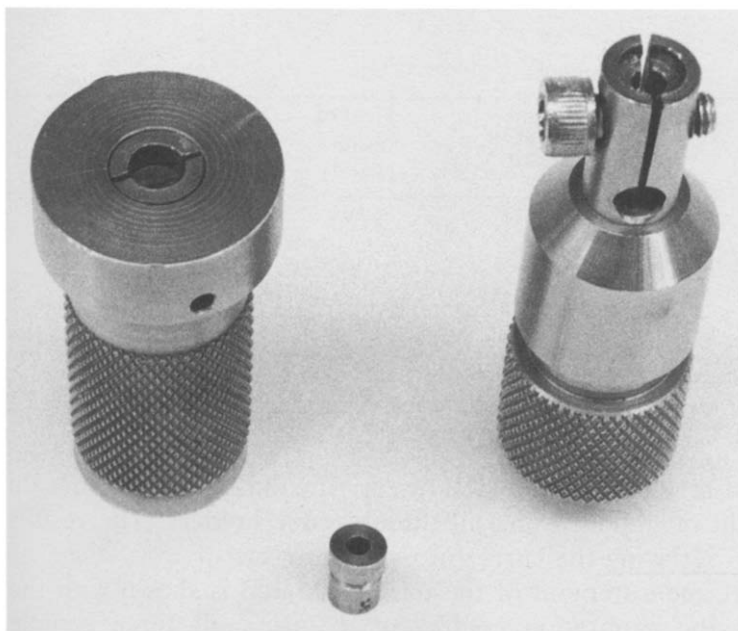

Plate 1. Set of wrenches. Left, wrench assembly (lower); centre, closed bomb; right, wrench assembly (upper).

The closed bomb's thermal characteristics (with and without a liner) are compared with those of a crimped aluminum pan with respect to heat transferability, repeatability of traces, quantitative data generation and pressure containment. The calibration coefficient  $E$  determined for the closed bomb (with and without a liner) and for a crimped aluminum pan will be compared.

#### EXPERIMENTAL

Three types of sample holder were used for the comparison of thermal characteristics and the determination of the calibration coefficient ( $E$ ): (1) TA [1] hermetic aluminum pans, (2) Merck closed bomb, and (3) Merck closed bomb with glass liner. The calibration coefficient ( $E$ ) was determined for a TA 910 DSC cell, using the TA 1090 thermal analytical instrument. The calibration coefficient ( $E$ ) was determined using a constant weight of indium and varying the heating rate and by using a constant heating rate and varying the weight of the indium sample. In each case  $E$  was determined by using the TA general analysis program. The thermal characteristics, with regard to heat transferability, were compared by determining the thermal resistance factor for the three sample containers, and are visually shown by overlaying the plots of the indium melt for the three types of sample holders. All of the indium melt curves used the same weight of indium and a  $5^{\circ}\text{C min}^{-1}$  heating rate.

TABLE 1  
Heat transfer ability

Container	Thermal resistance factor (°C mW <sup>-1</sup> )	Heat of fusion <sup>a</sup> (J g <sup>-1</sup> )	Calibration factor <sup>b</sup> <i>E</i>
Aluminum pan	0.2203	26.929	1.0557
Closed bomb (without liner)	0.4386	25.590	1.1110
Closed bomb (with liner)	1.2346	25.349	1.1202

<sup>a</sup> For heat of fusion data, *E* was set to 1.00.

<sup>b</sup> *E* (cal) = heat of fusion (theoretical)/heat of fusion (experimental).

Repeatability of results was evaluated by carrying out a series of runs on a consistent weight of indium using all three sample holders. The results are compared by overlaying the curves of the indium melt.

The quantitative measurement of the data generated is shown with the determination of the calibration coefficient *E* using all three sample crucibles, and by comparing the size of the exotherms from several proprietary Merck compounds, as determined using the three types of sample crucible.

Vapor pressure containment was evaluated by holding water, ethanol and acetone at  $\approx 10^\circ\text{C}$  above their respective boiling points for  $\approx 16$  h and comparing the weight of the solvent both before and after the aging. The same three samples were heated at  $5^\circ\text{C min}^{-1}$  until the seal ruptured to determine the closed bomb's pressure rating.

## RESULTS AND DISCUSSION

### *Heat transfer ability*

The thermal resistance of the closed bomb is approximately half that of the glass-lined closed bomb and twice that of the crimped aluminum pan. The heat transferability data are presented in Table 1 and shown in Fig. 2. A comparison of the calibration factors indicate that the closed bomb transfers  $\approx 5.5\%$  less heat to the detector than the aluminum pan and that the closed bomb, with a glass liner, transfers  $\approx 6.5\%$  less heat to the detector than the aluminum pan.

### *Repeatability of results*

The repeatability of results is demonstrated by overlaying five runs of the melt of indium for all three sample holders. The results are presented in

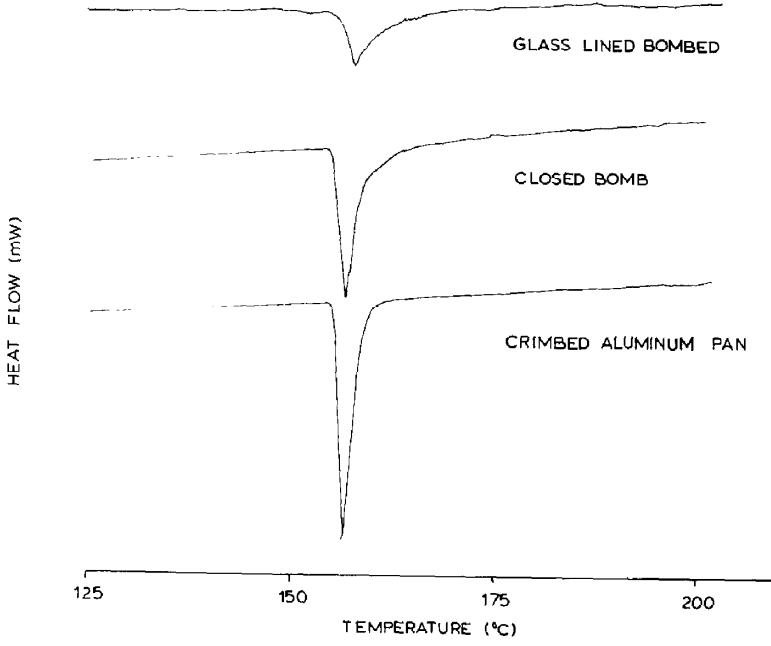

Fig. 2. Heat transferability data.

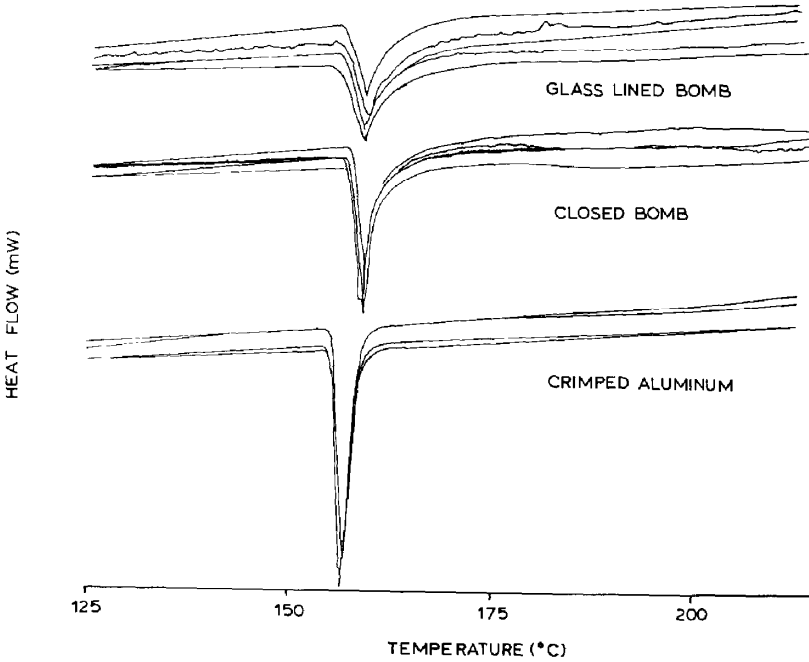

Fig. 3. Repeatability of results (offset vertically to allow comparison).

TABLE 2

Instrument calibration using indium: constant weight of indium (9.2 mg)

Cell type	Heating rate (°C min <sup>-1</sup> )	Heat of fusion <sup>a</sup> (J g <sup>-1</sup> )	<i>E</i> Experimental <sup>b</sup>	<i>E</i> Corrected <sup>c</sup>
Al pan <sup>d</sup>	1	27.661	1.0278	1.0414
Al pan	2	27.169	1.0464	1.0449
Al pan	5	26.929	1.0557	1.0552
Al pan	10	26.422	1.0760	1.0724
Al pan	20	25.370	1.1206	1.1069
Al pan	50	23.609	1.2042	1.2102
CB <sup>e</sup>	1	26.570	1.0700	1.1035
CB	2	26.397	1.0770	1.1097
CB	5	25.590	1.1110	1.1283
CB	10	24.519	1.1595	1.1592
CB	20	23.791	1.1950	1.2211
CB	50	20.235	1.4050	1.4068
GL <sup>f</sup>	1	26.940	1.0553	1.0807
GL	2	26.341	1.0793	1.0945
GL	5	25.397	1.1202	1.1142
GL	10	24.349	1.1676	1.1470
GL	20	23.480	1.2108	1.2128
GL	50	20.210	1.4067	1.4099

Theoretical heat of fusion for indium = 28.43 J g<sup>-1</sup>.<sup>a</sup> For heat of fusion data *E* was set to 1.000.<sup>b</sup> *E*(exp) = theoretical heat of fusion/experimental heat of fusion.<sup>c</sup> *E*(corrected) is the result of the straight line fit of data points where  $y = mx + b$ .<sup>d</sup> Al pan = crimped aluminum pan.<sup>e</sup> CB = Merck closed bomb.<sup>f</sup> GL = Merck closed bomb with glass liner.

Fig. 3. The results for the three different sample holders are off-set vertically to allow for better comparison. The repeatability for both the aluminum pan and the closed bomb is good. The relatively poor results obtained from the glass liner are a result of the loose fit of the liner and its movement, which resulted in changes in the position of the indium in respect to the bottom of the closed bomb.

### Quantitative measurement of data

The calibration coefficient *E* for the three types of sample holder was determined by utilizing a constant weight of indium and varying the heating rates and by utilizing a constant heating rate but varying the weight of indium. The results are presented in Tables 2 and 3 and in Figs. 4 and 5 respectively. The results indicate that the coefficient *E* increases linearly with increase in mass and heating rate, and the values obtained are consistent with those reported by Van Humbeeck and Bijvoet [2].

TABLE 3

Instrument calibration using indium: constant heating rate (5°C min<sup>-1</sup>)

Cell type	Weight of indium (mg)	Heat of fusion <sup>a</sup> (J g <sup>-1</sup> )	<i>E</i> Experimental <sup>b</sup>	<i>E</i> Corrected <sup>c</sup>
Al pan <sup>d</sup>	5.5	27.919	1.0183	1.0302
Al pan	9.2	27.169	1.0464	1.0403
Al pan	15.0	26.429	1.0757	1.0630
Al pan	19.4	26.049	1.0914	1.0781
Al pan	24.7	25.949	1.0956	1.0964
Al pan	29.8	25.658	1.1080	1.1140
CB <sup>e</sup>	5.5	25.426	1.0758	1.0835
CB	9.2	25.589	1.1110	1.0963
CB	15.0	25.126	1.1315	1.1198
CB	19.4	24.551	1.1580	1.1377
CB	24.7	24.199	1.1748	1.1591
CB	29.8	23.729	1.1981	1.1780
GL <sup>f</sup>	5.5	26.164	1.0866	1.0770
GL	9.2	25.379	1.1202	1.1144
GL	15.0	23.999	1.1846	1.1730
GL	19.8	22.879	1.2426	1.2174
GL	24.7	21.760	1.3065	1.2710
GL	29.8	21.061	1.3499	1.3222

Theoretical heat of fusion for indium = 28.43 J g<sup>-1</sup>.<sup>a</sup> For heat of fusion data *E* was set to 1.000.<sup>b</sup> *E*(exp) = theoretical heat of fusion/experimental heat of fusion.<sup>c</sup> *E*(corrected) is the result of the straight line fit of data points where  $y = mx + b$ .<sup>d</sup> Al pan = crimped aluminum pan.<sup>e</sup> CB = Merck closed bomb.<sup>f</sup> GL = Merck closed bomb with glass liner.

The decomposition exotherms for several proprietary compounds were determined using the three different sample holders, and are reported in Table 4. The results indicate that the sizes of the decomposition exotherms for the closed bomb with and without the glass liner are within  $\pm 1.5\%$ . With the crimped aluminum pans, the sizes of the decomposition exotherms

TABLE 4

Comparison of decomposition exotherms using the three sample holders

Sample No.	Size of decomposition exotherm (cal g <sup>-1</sup> )		
	Closed bomb	Glass liner	Aluminum pan
1	248.40	249.21	163.53 <sup>a</sup>
2	55.00	55.83	8.18 <sup>a</sup>
3	38.76	38.76	38.24

<sup>a</sup> The lid either leaked or was blown off before the exotherm was complete.

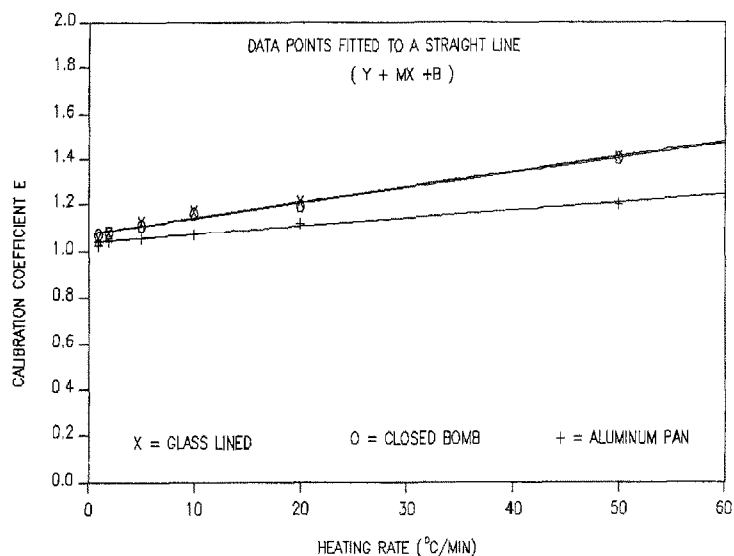

Fig. 4. Variation of  $E$  with heating rate at constant weight of indium.

vary considerably from those for the closed bomb. This is due to the problem of pressure containment associated with the crimped aluminum pan. In the case of sample 3, where the size of the decomposition exotherm for all three sample holders is approximately the same, the pressure generated was within the rating of the aluminum pan.

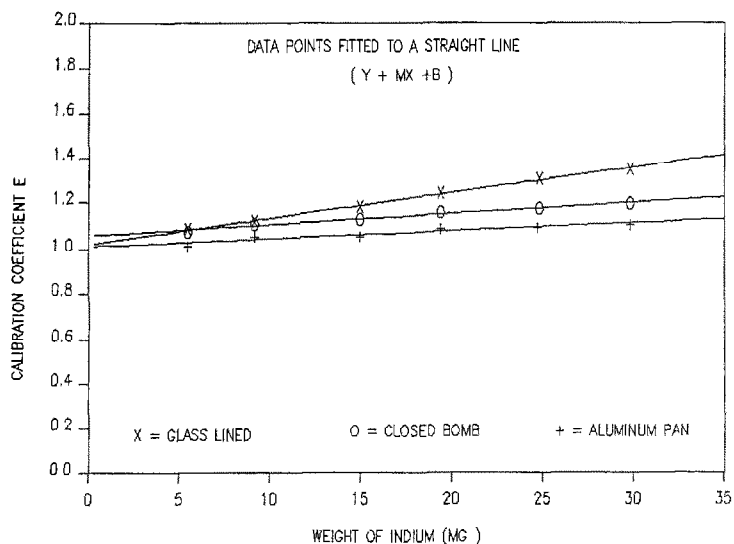

Fig. 5. Variation of  $E$  with weight of indium at constant heating rate.



TABLE 5

Closed bomb's vapor pressure containment

Part 1: vapor pressure rupture <sup>a</sup>

Sample	Lowest rupture pressure (psia)	Highest rupture pressure (psia)	Mean rupture pressure (psia)
Acetone	≈ 433	≈ 518	≈ 462
Methanol	≈ 445	≈ 530	≈ 498
Water	≈ 414	≈ 451	≈ 433

<sup>a</sup> The sample was heated until the teflon seal ruptured. Each run was repeated five times. The psia values reported are taken from Lange's Handbook of Chemistry.

Part 2: vapor containment <sup>b</sup>

Sample	Weight of sample before aging (mg)	Weight of sample after aging (mg)	Weight loss (%)
Acetone	67.4	67.3	0.15
Methanol	61.1	61.1	0.00
Water	58.5	58.5	0.00

<sup>b</sup> Each sample was heated to ≈ 10°C above its boiling point and held at that temperature for ≈ 16 h.

### *Pressure containment*

The ability of the closed bomb to contain vapor pressure is presented in Table 5. The results indicate that the closed bomb pressure rating is over 400 psi with weight losses of less than 0.1 mg ( $\leq 0.14\%$  weight loss) with highly volatile compounds.

### CONCLUSIONS

The Merck "closed bomb" is capable of providing accurate and reproducible thermal data for samples which must be run in a closed system. The closed bomb has high heat transfer capabilities and a pressure rating of over 400 psi. This closed bomb has been used in the Merck Operational Hazards Laboratory for many years, and has proven to be a reliable and dependable tool for determining exothermic activity in closed reaction systems.

### REFERENCES

- 1 TA Instruments, New Castle, DE.
- 2 J. van Humbeeck and Bijvoet, A calibration study of the Du Pont DSC 910 module, *Thermochim. Acta*, 120 (1987) 55.